

Hydraulic Cylinders & Accessories

Engineered for Excellence



Series B—Cross Tube Style 3000 PSI

Tube: ST 52.3 - Precision Honed for maximum seal performance and long life

Rod: Ground / Polished & Hard Chrome Plated for extended cylinder life

Rod Seal: Polyurethane Double Lip Design for lower friction / increased stability and positive sealing

Wiper: Polyurethane - Pressure Relief Ribs prevent pressure trapping

Piston Seal: Tough 92 A Polyurethane 775 Style face seal

- Providing excellent wear resistance
- High Extrusion resistance
- Tolerant to contamination
- Pre-loaded to ensure low pressure capabilities
- Suitable for single acting operation

Delavan Series B cylinders come standard with wear rings to protect from metal to metal contact caused by side loading or misalignment. Wear rings provide a consistent clearance gap for seals ensuring predictable operation and longer life expectancy.

Cross Tube Mounts fit a wide range of agricultural and mobile applications.



Hydraulic Cylinders & Accessories

Series B—Cross Tube Design

BORE	1.50	2.00	2.50	3.00	3.50	4.00	5.00
A	8.00	8.00	8.00	8.00	10.00	10.00	11.00
B	0.19	0.19	0.19	0.19	0.19	0.25	0.31
C	SAE #6	SAE #8	SAE #8	SAE #8	SAE #8	SAE #8	SAE #8
D	1.00	1.25	1.50	1.50	1.75	2.00	2.50
E	2.25	2.75	3.25	3.75	4.25	4.75	5.75
G	2.00	2.25	2.25	2.25	2.25	2.50	3.25
J	2.88	2.50	2.25	1.88	3.19	2.75	2.96
K	2.13	1.88	2.00	2.09	2.31	2.13	2.50
M	0.85	0.98	1.00	1.25	1.31	1.61	1.50
N	0.63	0.75	0.75	0.75	1.00	1.13	1.25
R	0.76	1.02	1.02	1.02	1.26	1.52	1.77
S	1.25	1.50	1.50	1.50	2.00	2.25	2.50

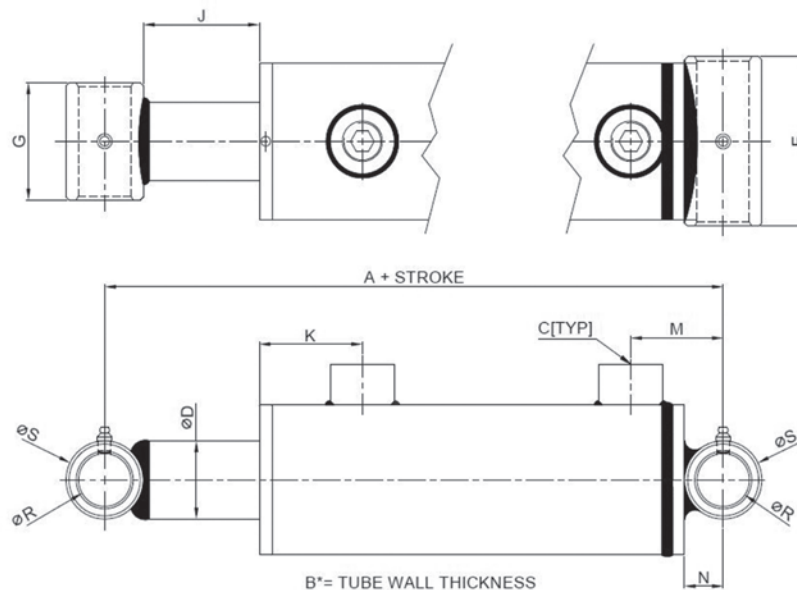

Engineered for Excellence

"We are committed to succeeding in today's increasingly challenging marketplace by responding to each varied and dynamic individual customer requirement with an exclusive and custom tailored solution."