

# Hydraulic Cylinders & Accessories

## Engineered for Excellence

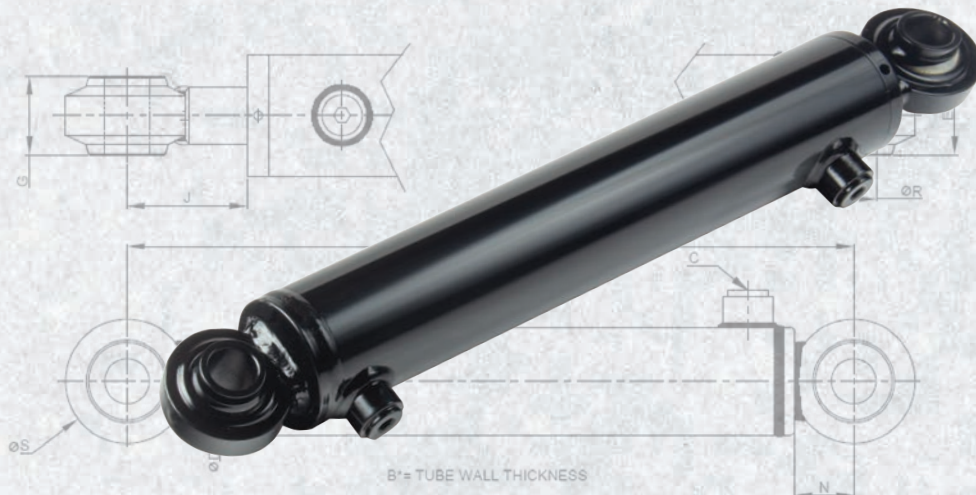

### Series A—Spherical Bearing Style 3000 PSI

**Tube:** ST 52.3 - Precision Honed for maximum seal performance and long life

**Rod:** Ground / Polished & Hard Chrome Plated for extended cylinder life

**Rod Seal:** Polyurethane Double Lip Design for lower friction / increased stability and positive sealing

**Wiper:** Polyurethane - Pressure Relief Ribs prevent pressure trapping

**Piston Seal:** Tough 92 A Polyurethane 775 Style face seal

- Providing excellent wear resistance
- High Extrusion resistance
- Tolerant to contamination
- Pre-loaded to ensure low pressure capabilities
- Suitable for single acting operation

Delavan Series A cylinders come standard with wear rings to protect from metal to metal contact caused by side loading or misalignment. Wear rings provide a consistent clearance gap for seals ensuring predictable operation and longer life expectancy.

Spherical Bearing Mounts are ideal for applications where mounting misalignment is common.



# Hydraulic Cylinders & Accessories

## Series A—Spherical Bearing Dimensions

BORE	1.00	1.50	2.00	2.50	3.00
A	6.00	7.25	7.50	7.50	8.25
B	0.19	0.19	0.19	0.19	0.19
C	SAE 6	SAE 6	SAE 8	SAE 8	SAE 8
D	0.63	1.00	1.25	1.50	1.50
E	1.00	1.00	1.75	1.75	1.75
G	1.00	1.00	1.75	1.75	1.75
J	1.83	2.42	2.02	1.93	2.13
N	0.95	0.96	1.32	1.32	1.50
R	0.50	0.75	1.00	1.00	1.00
S	2.00	2.00	2.00	2.75	3.12

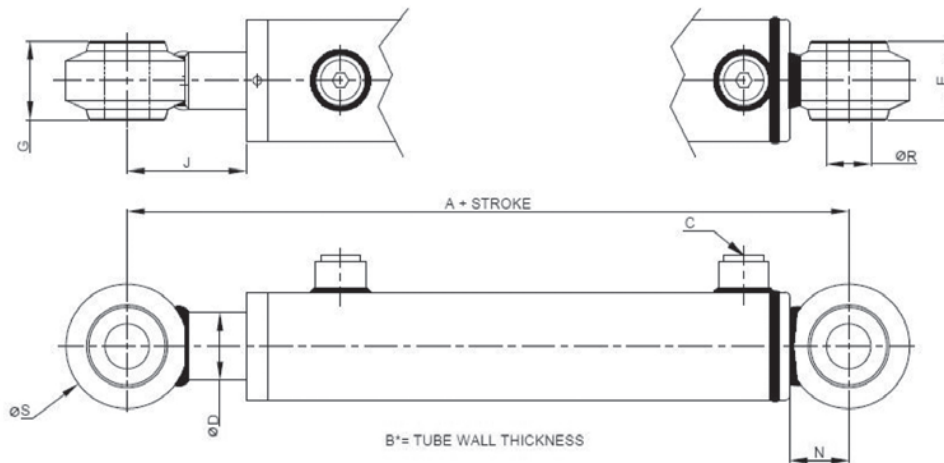

## Engineered for Excellence

*"We are committed to succeeding in today's increasingly challenging marketplace by responding to each varied and dynamic individual customer requirement with an exclusive and custom tailored solution."*