

HI-LOW HYDRAULIC GEAR PUMPS

INSTRUCTION MANUAL

Troubleshooting Chart

SYMPTOM	POSSIBLE CAUSE (S)	CORRECTIVE ACTION
Pump does not Develop full pressure	<ol style="list-style-type: none"> 1. System relief valve set too low or leaking 2. Oil temp is too high 3. Pump is worn out 4. Double acting cylinder piston seals are cut or worn out 	<ol style="list-style-type: none"> 1. Check system relief valve for proper setting with pressure gauge in outlet line 2. Let oil cool below 140°F 3. Replace worn parts or pump 4. Replace or repair cylinder
Motor won't start	<ol style="list-style-type: none"> 1. Lose connection 2. Circuit breaker tripped 3. Voltage drop 4. Seized pump 	<ol style="list-style-type: none"> 1. Check wiring 2. Reset circuit breaker 3. Use heavier gauge wire 4. Replace pump
Will not pump oil (motor runs but cylinder does not move, or moves slow)	<ol style="list-style-type: none"> 1. No oil in reservoir 2. Motor rotating wrong direction 3. Oil level low 4. Suction strainer is clogged 5. Double acting cylinder piston seals are cut or worn out 6. Reservoir breather is dirty or clogged 	<ol style="list-style-type: none"> 1. Check oil level, refill 2. Change rotation of prime mover or Reverse inlet and outlet hoses 3. Add oil as needed 4. Clean suction strainer 5. Replace or repair cylinder 6. Clean reservoir breather and reinstall
Pump motor unit is noisy	<ol style="list-style-type: none"> 1. Low oil level 2. Air in system 3. Suction strainer or inlet filter is clogged 	<ol style="list-style-type: none"> 1. Add oil as needed 2. Bleed air from highest fitting in system by loosening fitting very slightly and operating unit bubbling of air stops, then tighten. 3. Clean suction strainer or inlet filter clogged

Description

Our two stage, hi-low, external gear hydraulic pump, models 11GPM & 16GPM are designed to be direct-driven by gas engines or electric motors. They are suited for use in log splitters and other applications, such as: hydraulic lifts, platform lifts, die tables, automatic hoists, trash compactors, bench presses, machine tool lube systems, filter systems, clamping devices, and transfer systems, etc. They are ideal for press-type applications requiring fast approach/retract speeds and slower peak actuator work speeds because of horsepower limitations or safety constraints.

HI-LOW HYDRAULIC GEAR PUMPS

INSTRUCTION MANUAL

Unpacking

Due to cast iron construction. Very little damage can occur during transit. Do not remove the plastic shipping plugs from the ports until ready for installation. This will keep dirt or foreign material from entering the system.

Specifications

Model	11 GPM	16 GPM
Stage	2	2
Max. Operating Speed	3600	3600
Construction	"Front End: Iron Body: Aluminum"	"Front End: Iron Body: Aluminum"
Unloader Valve Setting	650 PSI	650 PSI
Mounting	4-Bolt 4F17	4-Bolt 4F17
Shaft Diameter	1/2"	1/2"
Inlet	1"	1"
Outlet	1/2 NPT	1/2 NPT
Pump Rotation	Clockwise	Clockwise

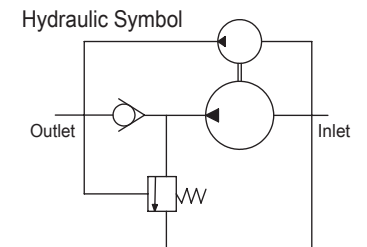
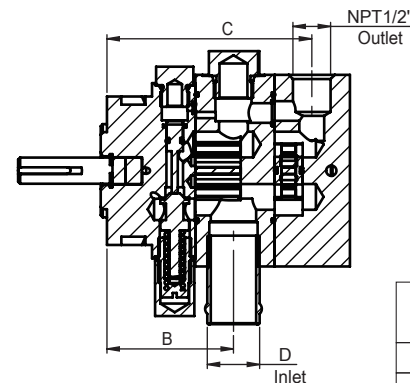
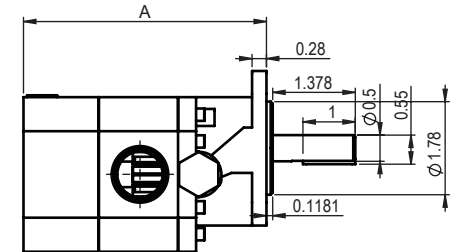
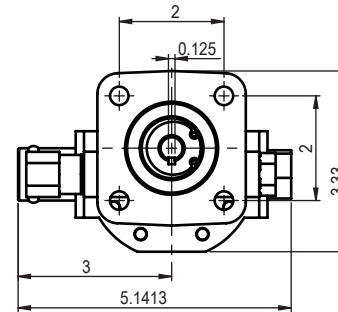

MODEL	DIMENSIONS			
	A	B	C	D
11 GPM	5.11"	2.74"	4.24"	1"
16 GPM	5.62"	3.31"	4.65"	1"

HI-LOW HYDRAULIC GEAR PUMPS

INSTRUCTION MANUAL

Performance Characteristics

		MODEL	
		11 GPM	16 GPM
Minimal Displ. (cu.in./rev.)	1 st stage	0.517	0.776
	2 nd stage	0.194	0.258
	Total	0.711	1.034
GPM@ 3600RPM	1 st stage	8.06	12.09
	2 nd stage	3.02	4.02
	Total	11.08	16.11
Max. Pressure (PSI)	1 st stage	900	900
	2 nd stage	3000	3000
Min. HP @3000 PSI (3600RPM)		5HP	8HP

When Outlet port pressure is under 650 PSI, Both stages are working and total displacement applies. Above 650 PSI, Only 2 nd stage displacement applies

WARNING

DISCONNECT POWER AND RELEASE ALL SYSTEM PRESSURE BEFORE SERVICING THIS EQUIPMENT

1. Follow all local electrical and safety codes, as well as the National Electrical Code (NEC) and the Occupational Safety and Health Act (OSHA)
2. Never exceed the maximum operating speed or pressure.
3. When using AC motors, ground the motor properly by wiring with a grounded, metal-clad raceway system, using a separate ground wire connected to bare metal of the motor frame, or other suitable means.
4. Guard all moving parts.

WARNING

RELEASE SYSTEM PRESSURE BEFORE SERVICING THIS EQUIPMENT.

5. Drain all liquids from the system before servicing.
6. Check hoses and connections for security before servicing.
7. Periodically check the pump and system components.
8. Provide a means of pressure relief for pumps whose discharge line can be shut off or obstructed.
9. Wear safety glasses at all times when working with pump.
10. Keep work area clean, uncluttered and properly lighted; replace all unused tools.
11. Keep visitors at a safe distance from the works area.
12. Make the workshop child-proof with padlocks, master switches, and by removing start keys.
13. Do not operate an engine in an enclosed area.
14. Do not spill gasoline on hot engine surfaces
15. Store gasoline only in an approved container.
16. Keep dirty and oily cleaning rags in a tightly closed metal container.
17. Check engine oil level before operating the engine.
18. Familiarize yourself with the controls and emergency shutdown procedures.
19. Never operate the equipment when you are fatigued.
20. All system components pressure ratings should be greater than maximum system pressure.
21. Put safety guards on all moving parts.
22. Keep all guards in place.

HI-LOW HYDRAULIC GEAR PUMPS

INSTRUCTION MANUAL

Installation



CAUTION

1. Do not overtighten fittings and bolts-this can damage the pump
1. Assemble one coupling half to the engine/ motor and tighten the set screw.
2. Assemble the other coupling half loosely to the pump shaft.

Note: Drive key dimensions in Specification section of this manual.



CAUTION

3. Do not force coupling onto pump shaft. A snap ring inside pump may be damaged by forcing coupling.
3. Insert the rubber spider into engine/motor coupling half.
4. Bolt the pump loosely to 4-bolt footmounted pump adaptor.
5. Align the shafts to make sure they are on center with each other.



CAUTION

6. Misalignment with shafts may result in premature shaft seal failure.
6. Tighten the mounting bolts.
7. Mate the coupling halves together, allowing 1/16" gap between halves.
8. Check the alignment again.



CAUTION

9. The gap in the coupling halves is to prevent end loading of the pump shaft.
9. Tighten the setscrew in the mating coupling halves.
10. Remove plastic shipping plugs from the inlet and outlet ports.
11. Squirt clean oil into pump for pre-lubrication and start-up.
12. Turn shaft coupling slowly to ensure proper shaft alignment and coupling installation.
13. Connect inlet line by slipping inlet hose over inlet tube and fasten with hose clamp.

NOTE: A few drops of oil on inlet tube beaded section will help ease the installation.

14. Keep inlet hose short and of adequate size to avoid pump cavitation.

NOTE: Cavitation is recognized by excessive pump noise.



CAUTION

15. Provide cooling for the hydraulic oil based on: duty cycle, pressure/flow, ambient temperature, oil and component maximum temperature specifications, and reservoir capacity.
15. Use a 1/2" NPT, high pressure fitting for the outlet port.

Use a good quality pipe joint compound (pipe dope) on all NPT Hydraulic fittings.



CAUTION

- Flush all lines to ensure contaminants have been removed.



CAUTION

- Do not use thread tape on NPT hydraulic fittings.



CAUTION

- Do not overtighten NPT pressure fitting in pump. This could distort or crack the pump gear housing.
16. At initial start-up, turn the drive shaft several times by hand to prime.
17. Bleed all air from the system to prevent erratic operation.
18. After several cycles, check the reservoir oil level and refill as necessary.

HI-LOW HYDRAULIC GEAR PUMPS

INSTRUCTION MANUAL

Operation

1. Check oil level before each use.
2. Follow operating instructions for engine or motor.

WARNING

DO NOT EXCEED THE PRESSURE RATINGS OF THE SYSTEM COMPONENTS A HYDRAULIC PRESSURE GAUGE IS RECOMMENDED IN THE HYDRAULIC CIRCUIT.

3. The unloading valve is adjustable up to 900 PSI by turning the adjusting screw clockwise.



CAUTION

Pressure gauge required when adjusting unloading valve.

NOTE: Increasing the unloading valve pressure will require increasing the pump drive horsepower. Factory preset, with a 400-900 PSI adjustment range.



CAUTION

If pump has not operated for an extended period of time, manually rotate pump shaft to prime and lubricate pump.

Maintenance

1. Keep the reservoir filled with hydraulic fluid.
NOTE: Use a good quality hydraulic oil.
2. Make frequent inspection of hydraulic fluid and change if contaminated.
3. To fill the reservoir with clean oil: Use a clean funnel fitted with a fine mesh wire screen. Do not use a cloth strainer. Most pump failure, valve malfunctions and short unit life can be traced directly to other foreign material (water, chips, lint, etc.) getting into, or already in, the hydraulic system.
4. Keep the unit clean of dirt and foreign materials.
5. Keep electrical connections clean.