



Features:

The Turbo™ 90 is designed to operate directly from a 1000 RPM PTO shaft without attachments. Peak performance at slower rotation means longer life of the seals. The Turbo 90 can pump suspended materials without accumulation unlike a conventional turbine pump. This is possible because of **Pressure Relief Passages** from the seal cavities to the inlet port. The suspension circulates, and therefore is cleaned from the inner cavities. It can be used for large quantity liquid transfer, from truck to tanks, for instance. It is well suited to high volume sprayer pumping applications.

The **impeller** is made of low moisture absorption, corrosion-resist, engineering grade thermoplastic. It has been designed to increase pump life and smooth operation because of less rotation weight. **Seals** available are either face seals or lip seals. Specify face seals for severe service (such as abrasives). Face seals feature hard, wear-resistant phenolic rings pressing against ceramic seats.

Bearings are isolated by drain cavities. **1 1/2" inlet and outlet ports** permit unrestricted high volume flow. Because of the high capacity of the Turbo 90, sufficient bypass flow is available to maintain maximum agitation. **Shaft** is made of stainless steel and has a 15/16" diameter with 1/4" keyway.

Turbo™ 90 Flow Rates — Gallons per minute

Pump Speed (RPM)	GALLONS PER MINUTE (GPM) AT POUNDS PER SQUARE INCH AT THE GAUGE (PSIG)										
	0	10	20	30	40	50	60	70	80	90	100
600	45	30	19	8	—	—	—	—	—	—	—
800	60	47	37	27	19	11	3	—	—	—	—
1000	75	65	55	46	37	30	24	18	12	6	—
1200	90	80	73	65	57	49	42	36	31	25	20

Severe Service model: A Turbo 90 pump is available with a **stainless steel impeller** and long life **face seals** for severe service. The stainless steel impeller will not swell or absorb chemicals because of its steel construction; is tough, durable and virtually indestructible; and is corrosion resistant.

Caution: Failure to use a suction strainer, as specified, may void the product warranty.

Note: A high capacity strainer with a 20-mesh screen must be used on the inlet side.

Note: A 1000 RPM PTO coupler must be used. The capacity or flow of the Turbo 90 pump used with a 540 RPM PTO coupler is about zero.

1000 RPM Quick Couplers: Quick couplers provide quick and simple on-off installation. The body is steel and the collar is Super Tough Nylon, color-coded International Orange for 35979, 1 3/8" PTO Coupler, and International Yellow for 35992, 1 3/4" PTO Coupler, according to safety standards.

Collar Coupler: This coupler reduces the chances of vibration because it clamps a full 360° on a 15/16" pump shaft, and on either 1 3/8" or 1 3/4" tractor PTO, like a collet. This provides better centering of the pump shaft to the tractor PTO. Both ends of the coupler must be wrench tightened onto the PTO shaft and the pump shaft prior to operation.

Note: Do not force coupler onto the PTO spline too far. 1/4" to 3/8" of PTO spline should be visible after coupler is in position.

Torque Bar and Chain: This part is needed to anchor a pump mounted directly on a PTO to keep it from turning with the PTO shaft.

Turbo 90 Repair Kits: 28455-1 repair kit for 26556-11 cast iron pump with face seals includes one gasket, two seal rings, for O-rings, two ceramic seats, two seat rings, two springs, and two seal supports. P/N 28455-2 repair kit for 26556-4 cast iron pump with lip seals includes one gasket and two lip seals.

Warning: When using PTO-driven equipment, leave shields in place. Do not wear loose-fitting clothing near rotating PTO shafts.

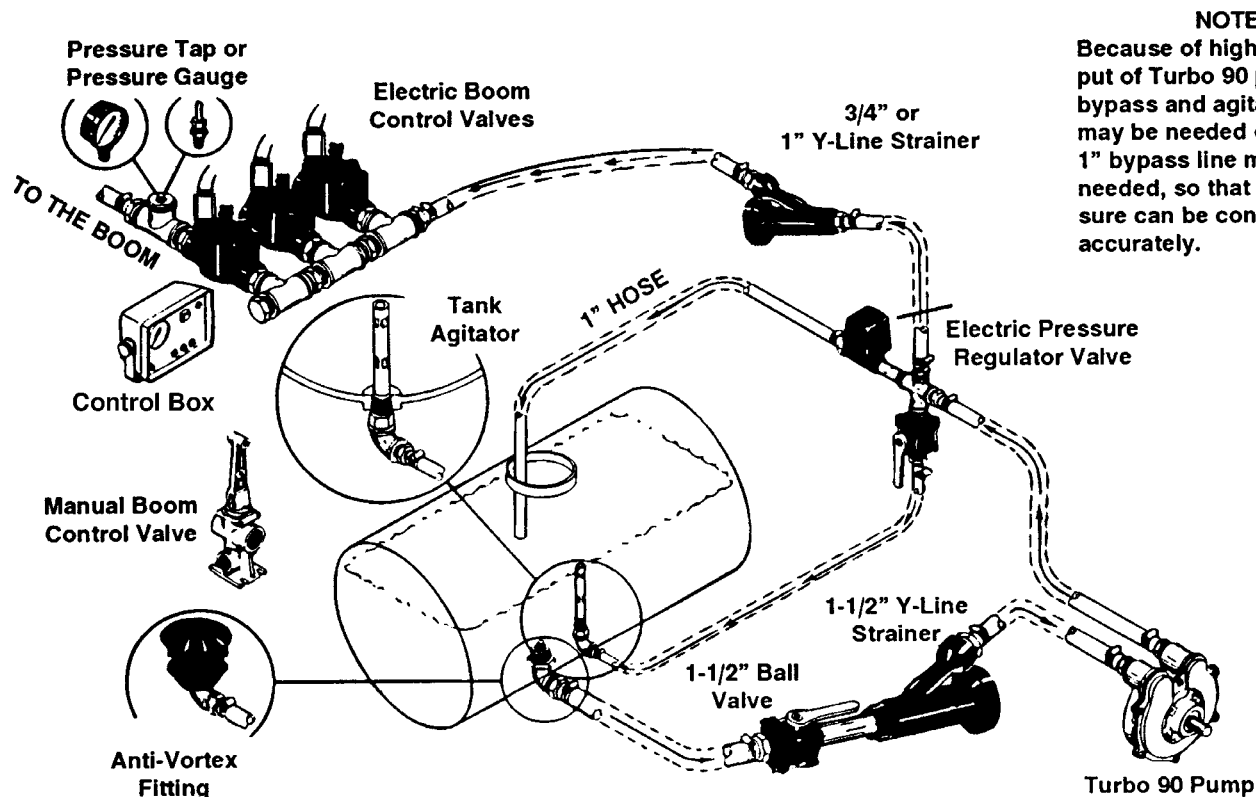

Figure 1. Plumbing for Pump Installation

Pump Installation

1. When using a quick coupler, line up key in the quick coupler with keyway on pump shaft and slide coupler into place, also lining up other set screw with spot on shaft. Tighten the set screw over the spot on the shaft first, then the keyway set screw.
2. When using quick couplers, pull collar back and slide onto the PTO shaft until it locks into place, release collar.
3. When using a Collar Coupler, slide onto pump shaft, then PTO shaft, leaving 1/4" to 3/8" of PTO spline visible. Tighten both ends of the coupler with a wrench.
4. Position pump below liquid level in tank to assure priming.
5. On other than PTO installations, check pump rotation. An arrow on the pump shows direction of rotation.
6. To keep pump from rotating with PTO shaft, use a torque bar and chain assembly 33680 (Fig. 3). Bolt bar to pump, using two adjacent flange bolts. Snap one end of chain to the torque bar and the other end to a stationary part of the tractor. Mount the torque bar so the counter force will raise up on

the pump and help relieve the side pressure due to weight of the pump and hose. Do not fasten pump rigidly to the tractor.

7. With the pump in position, connect the inlet hose to the IN port. Use a 1 1/2" I.D. hose if you need maximum flow rates (Fig. 1).

Note: Support hoses where necessary to keep weight off the pump.

Caution: Failure to use a suction strainer, as specified, may void the product warranty.

8. A high capacity strainer with a 20-mesh screen must be used on the inlet side (Fig. 1).
9. For in-line protection of nozzles, use a 40-mesh strainer in the boom feed line. Use a 3/4" or 1" Y-type strainer (Fig. 1).
10. To regulate pressure, install either a 1 1/4" ball valve or 1" pressure regulating valve downstream from the pump discharge (Fig. 1). Do not use a spring-loaded valve.
11. Check all hose connections. Loose connections can permit air to be drawn in and the pump may not prime properly.

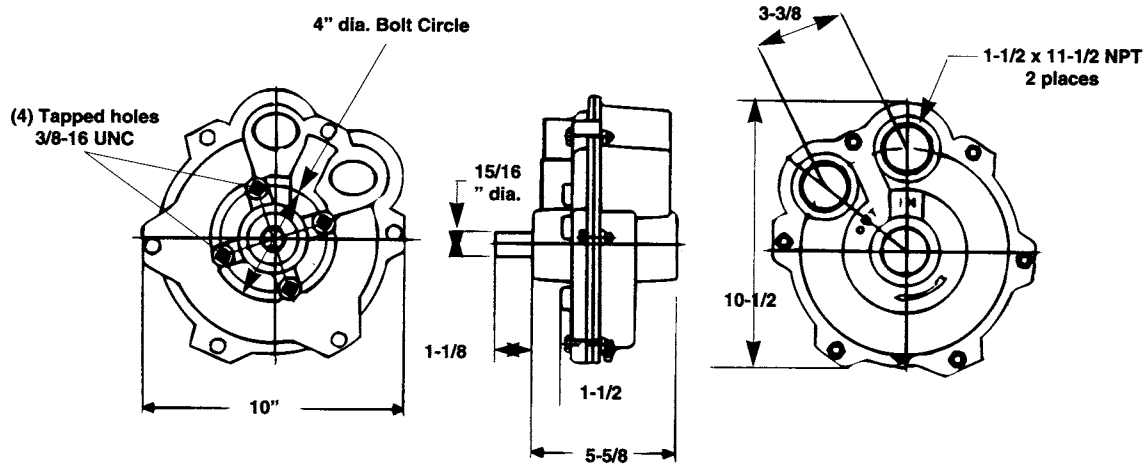

Figure 2. Dimensions

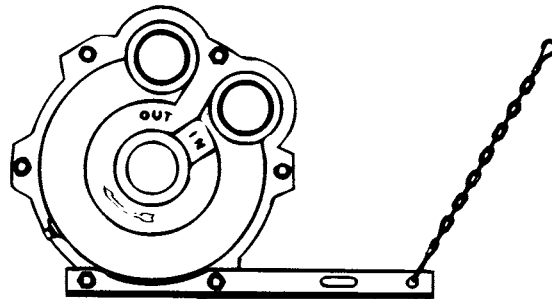

Figure 3. Torque bar and chain assembly, installed

Pump Operation

1. Before starting, make sure all air is removed from pump and lines.
2. Do not use rusty supply barrels or sandy water.

Caution: Running pump dry can cause excessive heat and damage seals.

3. Do not start pump before priming. The pump is NOT self-priming. Be sure suction line and pump are filled with liquid. Open the pressure regulating and boom regulating valves to be sure there is no back pressure on pump. Do not close the discharge line of the pump unless a means of bypassing the liquid relief valve has been installed. Pump can then be started and should prime. To assure ease in prime and the bleeding of air in pumping system, install pump so that ports are upright.

Caution: Operating above maximum limits can damage pump.

4. Do not operate pump at a PTO speed in excess of 1250 RPM, or a pressure higher than 100 psi (7 bars), or a temperature higher than 120° F (50° C).

Pump Maintenance

1. Bearings require no lubrication.
2. Drain. If pump remains installed on tractor, remove drain plug to drain pump. If pump has been removed from tractor, use IN and OUT ports for draining.
3. Flush. After use, thoroughly flush pump with clear water. If available, use a solution of one cup of ammonia in 10 gallons of water. This will dissolve most residue remaining in the pump. Drain, let dry, then flush pump with light lubricating oil.
4. Store.

Caution: Gasoline, kerosene or fuel oil can attack materials in pump. Do not use as storing solution.

If pump is to be stored, follow flush with a 50 percent permanent antifreeze solution. Plug ports.

Maximum Recommended Pressure:
100 PSIG (7 Bars)

Maximum Recommended Temperature:
120° F (50° C)

Maximum Recommended PTO Speed:
1250 RPM

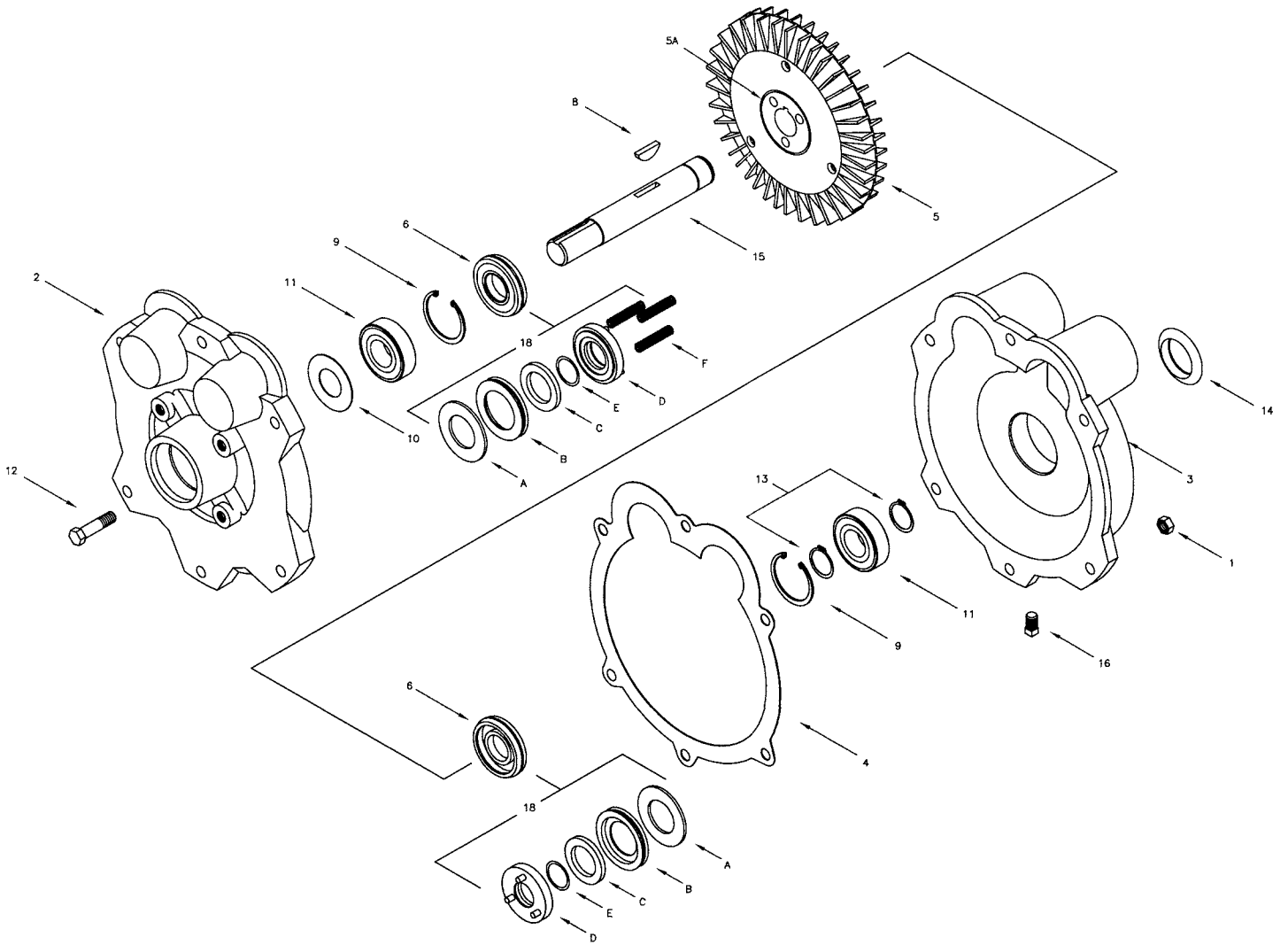

Figure 5. Turbo™ 90 Exploded View

Note: Turbo 90 pumps, P/N 26556-11 are equipped with face seals. These seals are six-piece assemblies, P/N 51387. Replace worn face seals with P/N 51387. Be sure Wave Spring side is toward impeller (5).

Note: Turbo 90 pump P/N 26556-4 is equipped with lip seals. These seals are two-piece assemblies which include a seal and a seal adapter in each.

If your pump is equipped with two-piece seal assemblies, use P/N 45005 (Turbo 90 Lip Seal) as the replacement seal. This seal is about 1 3/4" in diameter.

If the seal adapter has been damaged, use P/N 45006 as the replacement adapter. When replacing seal, be sure spring side faces liquid flow.

Turbo™ 90 Pump and Accessories Parts List

REF. NO.	PART NO.	DESCRIPTION	QUANTITY REQUIRED 26556-	
			4	11
	26556-4 26556-11	Cast Iron T-90 Pump Assembly with lip seals and thermoplastic impeller Cast Iron T-90 Pump Assembly with face seals and thermoplastic impeller		
1	17902	Hex Nut (3/8"-16 UNC)	6	6
2	39923-1	End Plate, Cast Iron	1	1
3	39924-1	Body, Cast Iron	1	1
4	26545	Gasket	1	1
5	28709	Impeller, Thermoplastic	1	1
5a	30512	Hub	1	1
8	26544	Woodruff Key	1	1
9	26548	Snap ring, Internal	2	2
10	26665	Dust Shield	1	1
11	16228	Bearing, Shielded	2	2
12	39934	Cap Screw, Hex Head (3/8"-16 UNCx1 5/8")	6	6
13	26547	Snap ring, External	2	2
14	39935	Cap	1	1
15	34793	Shaft	1	1
16	25785	Pipe Plug, Square Head	1	1
17	45005	Lip Seal Assembly - Includes Lip Seal and Adapter	2	—
18	51387	Face Seal Assembly	—	2
A	31352-225	Washer		
B	51210	Ceramic Seat		
C	51211	Seal Ring		
D	31352-214	O-Ring		
E	51212	O-Ring		
F	51213	Wave Spring		
Repair Kits	33680	Torque Bar and Chain Assembly	—	—
	28455-1*	Repair Kit for 26556-11, pumps with Face Seals (includes one P/N 26545, gasket, and one P/N 51387, Face Seals)	—	—
	28455-2*	Repair Kit for 26556-4, with Lip Seals (includes one P/N 26545, gasket and two P/N 45005 lip seal assemblies)	—	—

****Both repair kits may be used in all Turbo 90 pumps.***

Parts List

To avoid confusion and possible delays when placing an order, always specify the Part Number and Description.

To find the correct part number, first locate the part in the exploded view to the left and note the reference number.

Then, using the corresponding reference number in the chart above, find the part number in the parts list. All parts are available through your dealer.

The numbers in parentheses are reference numbers that are found in the exploded view on page 4. Underlined parts are included in repair kits, and can be discarded if using kit.

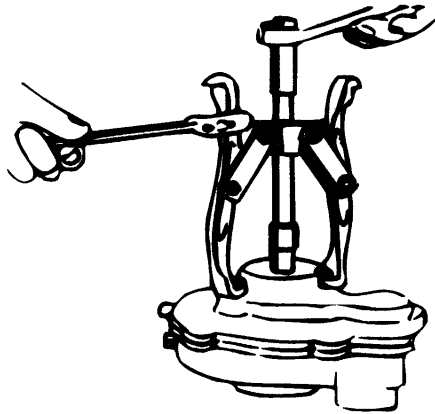

Figure 6. Pulling end plate from body

Pump Disassembly

1. If coupler is on pump shaft, remove.
2. With a 9/16" wrench, unscrew 6 nuts (1) from capscrews (12) and remove capscrews.
3. Screw two screws (12) into opposite threaded holes on end plate (2). Install puller (Fig. 6). Tighten puller with a wrench to pull end plate (2) from body (3). Lift off end plate (2).

Note: Although a puller is recommended, you can separate the end plate (2) from the body (3) by using a 1" diameter brass rod at the shaft end, tapping it with a hammer.

4. Remove gasket (4).

Note: Snap rings (9,13) bearings (11) and shaft (15) should not be removed unless damage has occurred.

5. Use snap ring pliers to remove snap ring (9) from end plate (2).
6. To remove bearing (11), push out with arbor press or use a small piece of brass rod and gently tap with hammer.
7. Remove dust shield (10).
8. Use snap ring pliers to remove snap ring (9) from body (3).
9. Using screwdriver, pry nameplate (14) from body (3).
10. Push shaft (15) and bearing (11) out of body (3) with an arbor press or by using a small piece of brass rod and tapping with hammer.
11. Remove snap rings (13) from shaft (15).
12. Press bearing (11) from shaft (15).
13. **P/N 26556-11, pump with face seals (skip to next section if your pump has lip seals):**
 - a. Pry out ceramic seat (B) and seat ring (C) from end plate (2).
 - b. Lift out dust shield (10) from end plate.
 - c. Slide seal ring (C) with O-ring from shaft.
 - d. Lift out three springs (F) from impeller (5).
 - e. Lift impeller (5) from body (3).
 - f. Remove Woodruff key (8) from shaft.
 - g. Slide other seal ring (C) with O-ring from shaft.
 - h. Pry out ceramic seat (B) and seal ring (C) from body (3).
 - i. Remove dust shield (10) from body.

14. P/N 26556-4 pump with lip seals (return to previous section if your pump has face seals):

- a. Lift impeller (5) from body (3).
- b. Remove Woodruff key (8) from shaft (15).
- c. Using screwdriver, pry nameplate (14) from body (3).
- d. Remove snap ring (13) from pump shaft.
- e. Push the pump shaft out using an arbor press or a small brass rod by gently tapping with a hammer.
- f. Using a drift punch, from the painted side of each casting, drive the old lip seal (17) out by hitting on the old seal case. Discard old lip seals.

Pump Assembly

Preparation

1. Thoroughly clean all metal parts in solvent with a soft-bristle brush.
2. Coat metal parts with light lubricating oil to assure easier assembly.
3. Obtain repair kit 28455 which contains parts listed on the parts list, page 5. Replace all old parts with new parts from repair kit.

Assembly

1. If bearings (11) were removed, lightly oil bearing cavities.
2. Place dust shield (10) in end plate (2) and, applying pressure to outer bearing race, press bearing (11) downward until it bottoms.
3. Install snap ring (9) in end plate (2).
4. Press other bearing (11) into body (3).
5. Install snap ring (9) in body. Install inner snap ring (13) on shaft (15) and press shaft into bearing (11). Install outer snap ring (13) on end of shaft (15).
6. **P/N 26556-11, pump with face seals (skip to next section if your pump has lip seals):**
 - a. Place seal support (A) in body (3).
 - b. Place the ceramic seat into the pump body all the way down on the O-ring (A).

Note: Ceramic seat (B) is installed with O-ring groove and side with marking toward the outside of the pump.

- c. Lubricate the O-ring groove on the ceramic seat (B) with clean oil or petroleum jelly. Place the ceramic seat into the body. Carefully force the seat down over the O-ring until it is against the seal support.

Caution: The ceramic seat may be cracked or broken if it is placed in the body cocked or if excessive force or metal objects are used to drive it in place.

- d. Slide the new seal ring (C) onto the shaft with the internal O-ring groove toward the inside of the pump. The small diameter of seal ring should mate with the ceramic seat.

- e. Slide the small O-ring (D) onto the shaft. Push the O-ring out of the key way to avoid cutting the O-ring. Push the O-ring into the groove in the seal ring.
 - f. Slide the small washer (E) over the shaft and into the recess in the seal ring.
 - g. Slide the wave spring (F) over the shaft and onto the washer (E). The spring will rest against the impeller hub.
 - h. Install the face seal in the end plate (2) in the same way as into the body (3).
6. **P/N 26556-4 pump with lip seals (return to previous section if your pump has face seals):**
- a. Install lip seals (P/N 45005) using sealant such as Permatex on the mating surfaces. Press to the bottom of the seal bores in both end plate and body. See exploded view, page 4.
 - b. Tap lip seal (17) into pump body using pipe nipple or seal driver of a diameter large enough to push on the inside of the concave side of the seal. The cupped, concave side of the seal faces towards the inside of the pump. The spring faces toward the liquid flow.
 - c. Make sure the seal bottoms against the seal supporting edge machined into the casting.
 - d. Install Woodruff key (8) in shaft (15). Be sure the key bottoms.
- e. Slide impeller (5) onto shaft.
 - f. Tap lip seal (17) into end plate adapter (45006) using pipe nipple or seal driver. Cupped or concave side goes toward the inside of pump; spring faces toward liquid flow.
 - g. Make sure the seal bottoms against the seal supporting edge machined into the casting.
- 7. Place gasket (4) on body (3).
 - 8. With an arbor press, press on inner race and press end plate (2) onto shaft (15).

Caution: Uneven tightening of nuts (1) and capscrews (12) to pull end plate (2) down can crack casting.

Note: Although an arbor press is recommended, if none is available, you can pull end plate onto body by carefully tightening nuts (1) and capscrews (12).

- 9. Install capscrews (12) and nuts (1) and tighten.
- 10. Turn shaft to be sure the pump is not binding. If pump seems to be binding, tap shaft lightly with a soft hammer.
- 11. Replace nameplate (14) in body (3). Nameplate is merely pushed into place.

Turbo™ 90 Troubleshooting Guide

PROBLEM	CAUSE	PROCEDURE
1. NO PRESSURE, OR NO CAPACITY	<ul style="list-style-type: none"> a. Inlet line not immersed in liquid or low level b. Pump not primed c. Plugged strainer d. Intake line air leaks e. Intake line blocked f. Pump turning wrong direction g. Pump parts worn 	<ul style="list-style-type: none"> a. Reposition inlet line or fill tank. b. Prime pump; be sure mounted below water level. c. Clean strainer with water and soft brush if needed. d. Tighten all connections, using pipe joint compound. Check hoses for leaks. e. Check line and clean. f. Check direction of arrow on pump, mount correctly. g. Replace using Repair Kit, or return for repair or if under warranty.
2. EXCESSIVE NOISE OR VIBRATION	<ul style="list-style-type: none"> a. Loose couple b. Bent or damaged shaft, improperly aligned c. Intake line leaks; plugged strainer d. Worn parts, broken rotor vanes 	<ul style="list-style-type: none"> a. Tighten or replace coupler. b. Replace shaft. c. See PROCEDURES c. and d. above. d. See PROCEDURE g. above.
3. PUMP RUNS, BUT LOW CAPACITY	<ul style="list-style-type: none"> a. PTO speed too slow. b. Intake line partially blocked or too small c. Too many fittings, elbows, valves d. Plugged strainer or leaks 	<ul style="list-style-type: none"> a. 1000 RPM required. b. Clean line. Use 1 1/2" I.D. hose. c. Replumb for more direct path. d. See PROCEDURES c. and d., block 1.
4. PRESSURE AT PUMP, BUT LOW OUTPUT AT NOZZLES	<ul style="list-style-type: none"> a. Nozzle orifice too small or strainer plugged b. Discharge line too small c. Valves set incorrectly 	<ul style="list-style-type: none"> a. Replace nozzles; clean nozzle strainer. b. Use 1 1/2" I.D. hose. c. Check, adjust valves.
5. IMPOSSIBLE TO ROTATE SHAFT	<ul style="list-style-type: none"> a. Improper assembly b. Foreign material or corrosion in pump 	<ul style="list-style-type: none"> a. Gasket in place? Review assembly instructions. b. Disassemble and clean. Use clean water supply.
6. LEAK	<ul style="list-style-type: none"> a. Lip seal installed backward b. Worn parts c. Worn casting 	<ul style="list-style-type: none"> a. Check drawing page 4. Spring should be toward liquid. b. Repair using repair kit. c. Replace pump.

Returns

All Delavan products are warranted against manufacturing defects (see warranty, below). In the event you feel you have a warranty-covered, returnable item, return the pump to your dealer, who will replace a warrantable pump for you. Delavan's "No Hassle Warranty" puts you back in the field sooner!

Important:

Whether you are returning your pump for warranty or for repair, you must do the following:

1. Flush chemical residue from the pump (best done in the field).
2. Tag pump with type of chemicals having been sprayed.
3. Include complete description of operation problem, such as how pump was used, symptoms of malfunction, etc.

Since pumps can contain residues of toxic chemicals these steps are necessary to protect all the people who handle return shipments, and to help pinpoint the reason for the breakdown.

Delavan Products Warranty

All products sold by Delavan are warranted only to purchasers from Delavan for resale or for use in purchasers' own business or original equipment manufacture, against defects in workmanship or materials under normal use, maintenance and service (rental use excluded), if notice of said defect is received by Delavan at the factory within 90 days after installation or one year from date of shipment from the factory, whichever first occurs. The sole and exclusive obligation of Delavan under this or any implied warranty shall be to replace or, at its option, to repair, without charge, any product which is determined by Delavan to be defective in workmanship or materials after the product is returned to the Delavan factory, shipping costs prepaid. In no event

shall Delavan be liable to any person for indirect or consequential damages or for injury or commercial loss resulting from any use or inability to use and Delavan product. Delavan expressly negates any other warranty, express or implied, including any warranty of merchantability or fitness for a particular purpose, or arising from any course of dealing or custom or usage of trade. No person, including any dealer or representative of Delavan, is authorized to make any representation or warranty on behalf of Delavan in addition to or inconsistent with these provisions. Purchasers to whom these provisions apply agree to hold Delavan harmless from claims by their customers in excess of the obligations of Delavan expressly set forth herein.

DELAVAN[™]
PUMPS, INC.

1228 Chestnut Ave. • Minneapolis, MN 55403
Toll Free: 1-866-DELAVAN (335-2826)
(612) 333-3189
Toll Free Fax: 1-888-726-5906
(612) 333-3231