

Turbo90

PTO-DRIVEN
Turbine Pump

Turbine Pumps & Accessories

Delavan Turbo90 PTO pumps are durable transfer pumps built specifically for your various applications. Turbo90 features are designed to power all your farm and field accessories with ease.



DELAN**AN**

Discover the Delavan Difference

Turbo90

PTO-DRIVEN
Turbine Pump



TURBO 90 Series

26556-4 – Turbo90 with standard duty lip seals
26556-11 – Turbo90 with severe duty face seals

Pump:

Type: Turbine, cannot run dry
Max pressure: 100 PSI
Max Recommended Temperature: 120°F
Inlet/Outlet Ports: 1 1/2 NPT (female)
Shaft Diameter: 15/16" with 1/4" keyway
Shaft Rotation: CCW
Weight: 23 lbs.

Materials of Construction:

Pump Housing: Cast Iron
Impeller: Nylon
Seals: Lip style or face seal (Viton)
Shaft: Stainless Steel

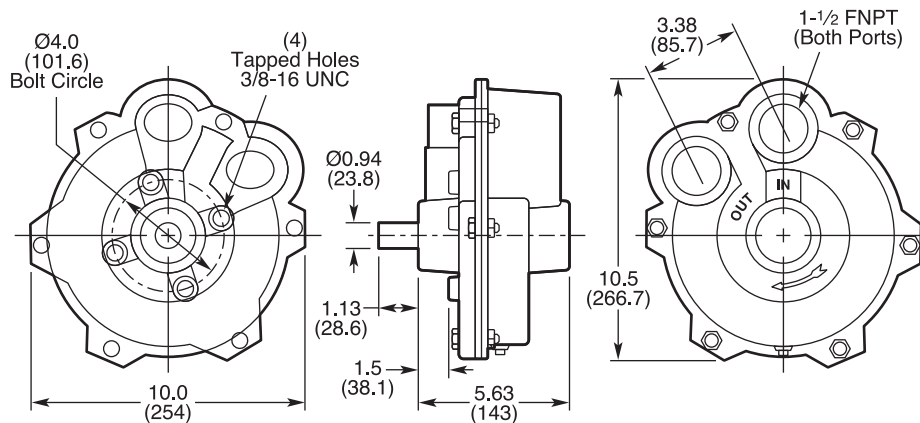

TURBO 90 Series Performance

PSIG	600 RPM	800 RPM	1000 RPM	1200 RPM
0	45	60	75	90
10	30	47	65	80
20	19	37	55	73
30	8	27	46	65
40		19	37	57
50		11	30	49
60		3	24	42
70			18	35
80			12	31
90			6	25
100				20

Turbo 90 Repair Kits

Kit contains appropriate style seals, gasket, and instructions.

Turbo 90 Face Seals – for T90 26556-11 Part# 28455-1

Turbo 90 Lip Seals – for T90 26556-4 Part# 28455-2

Accessories

Torque Bar and Chain – Required to anchor PTO-mounted Turbo 90 pump in order to keep pump from rotating with the shaft.

Couplers – These provide quick and simple on-off installation. Recommended couplers for the Turbo 90 are couplers with part number:

90100 – For 1-3/8" diameter PTO shaft; 9-tooth; 540-1000RPM

90700 – For 1-3/8" diameter PTO shaft; 6-tooth; 540 RPM

90500 – For 1-3/8" diameter PTO shaft; 21 tooth; 1000RPM

90800 – For 1 3/4" diameter PTO shaft; 20 tooth; 1000RPM

**A 1000-RPM PTO coupler must be used. The Turbo-90 can be operated at lower speeds, but the capacity diminishes dramatically with speed – at 540 RPM the capacity is almost zero. A choice of four quick couplers is available.*



28455-2 Lip Seals
Repair Kit



28455-1 Face Seals
Repair Kit



90800 Coupler